

CONTINUOUS BACKWASH SAND FILTERS



Blue Water's Centra-flo™ filters have been designed to maximize performance. In every application involving granular media filtration, the Centra-flo™ continuous backwash sand filter is the premier choice for the removal of suspended and colloidal solids. Classified as an upflow, dynamic bed filter, Centra-flo™ provides a continuous supply of high quality filtrate without interruptions for backwash or cleaning cycles.

Regardless of the application or industry, the clear solution for tertiary filtration is Centra-flo™. Throughout the USA and around the world, Centra-flo™ filters are helping clients meet discharge targets and NPDES permits as efficiently and as economically as possible. As the vessel for Blue Water's patented Blue PRO® and Blue NITE™ advanced nutrient removal processes, the Centra-flo™ filter incorporates proprietary internal assembly designs and control systems into its carefully considered configuration. Whether your purpose is metals removal, solids polishing, or nutrient removal, Blue Water can help you reduce process costs and achieve optimum performance.

With over twenty years of international installation history and experience, Centra-flo™ filters have established a reputation in the wastewater industry for providing effective solutions to municipal and industrial clients alike.



0.75 MGD (33 L/s) Centra-flo™ installation in New York

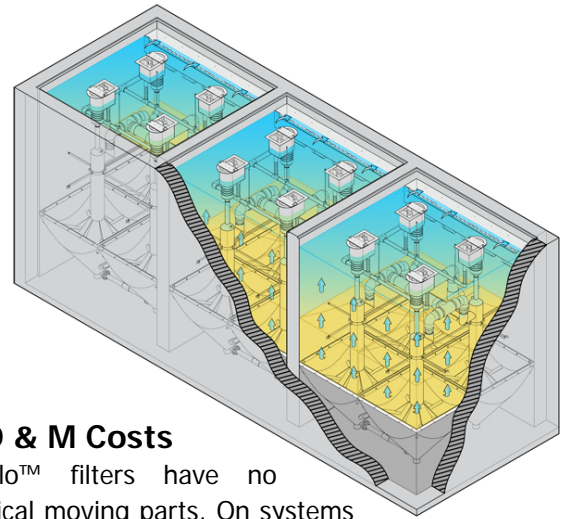

Low O & M Costs

Centra-flo™ filters have no mechanical moving parts. On systems designed for gravity feed flow, there are no pumps, valves, or complex control systems. The only operating cost incurred by the customer is the air consumption of the airlift. Each airlift, which continuously circulates spent media to the washbox, consumes between 1 to 3 scfm at 40 psi (1.7 to 5 m³/h at 275 kPa gauge). With quality components designed for longevity and minimal media loss, Centra-flo™ systems guarantee customers minimal O & M costs.

Centra-flo™ filters meet and exceed the most stringent construction requirements in the industry. Blue Water provides the Centra-flo™ filter in either fiberglass reinforced plastic or stainless steel for circular above-ground installations and rectangular concrete modules in below-grade hydraulic profiles.

Several ancillary system options are available for specific customer needs including Seismic 4 designed tanks and heat tracing or insulated tanks where climate extremes are anticipated.

Centra-flo™ Applications:

Industrial

- Metals Removal
- Mill Scale
- Pulp and Paper Process Water
- Surface Water
- Oil/Emulsion Waste
- Cooling Towers
- Mining

Municipal

- Potable Water Filtration
- Water Reuse: CA Title 22 Accepted
- Tertiary Filtration
- Algae Removal, Lagoons
- Phosphorus Removal
- Denitrification
- Metals Removal

Filter Operation

Influent process water (1) enters the filter through a central feed chamber. At the bottom of the feed chamber (2) a set of radial arms (3) evenly distributes the process water to the media bed. Water flows upward through the filter, and the media (4) retains suspended solids, contaminants, and nutrients depending on the application. The purified filtrate (5) fills the headspace above the media bed and flows over a fixed effluent weir (6) at the top of the filter. A portion of the filtrate passes through the washbox (7) at the top of the central assembly and carries away the separated solids, contaminants, and nutrients in the reject stream (8).

Centra-flo™ is a gravity sand filter and utilizes counter-current filtration. As the airlift (9) transports the dirtiest sand to the washbox, the media bed moves downward at a steady rate. Solids and contaminants retained by the filter media are drawn downward into a recessed chamber in the filter's lower cone. The high-energy turbulence inside the airlift provides a scrubbing action that effectively separates the sand and the captured solids before discharging them to the washbox at the top of the filter. The washbox is a baffled chamber that allows for counter-current washing and gravity separation of the filter media and the lighter captured solids. The separated solids and contaminants are carried away by the reject portion of the filtrate, while the scrubbed media falls by gravity to the top of the filter bed.

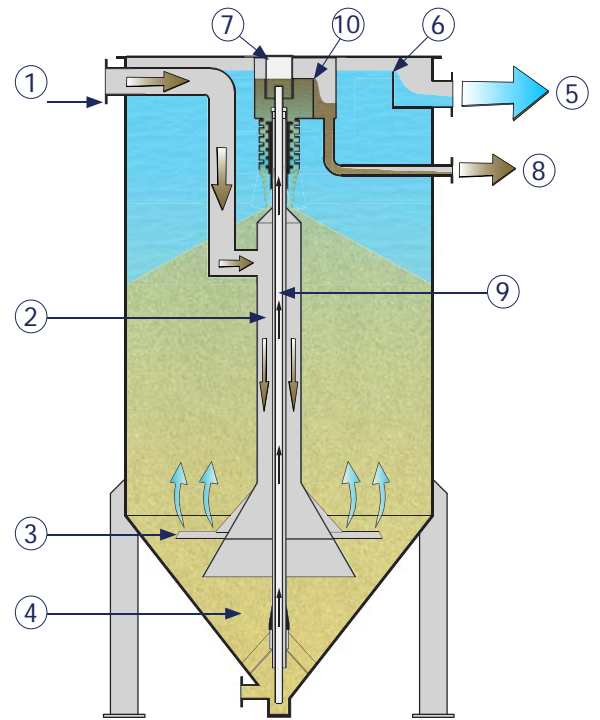

- | | |
|------------------------------|------------------------|
| 1. Influent | 6. Fixed Effluent Weir |
| 2. Central Feed Chamber | 7. Washbox |
| 3. Radial Arms | 8. Reject |
| 4. High Quality Silica Media | 9. Airlift |
| 5. Filtrate | 10. Adjustable Weir |

Below Ground Rectangular Concrete Models

Model No.	Area (ft ²)	WxL (ft)	Height (ft)	Modules	Loading (gpm)	Reject (gpm)	Air (scfm)
CF-50-UF	50	7'-1"x7'-1"	18'-2"	1	75-250	10-15	2-3
CF-64-UF	64	8'-1"x8'-1"	18'-8"	1	100-320	10-15	2-3
CF-200-UF	200	14'-2"x14'-2"	18'-2"	4	300-1000	40-60	8-12
CF-256-UF	256	16'-2"x16'-2"	18'-8"	4	300-1280	40-60	8-12

Above Ground Circular Models

Model No. (FRP, CS, SS)	Area (ft ²)	Diameter (ft)	Height (ft)		Loading (gpm)	Reject (gpm)	Headloss (in) optimal	Air (scfm)
			40" bed depth	80" bed depth				
CF-7-UF	7	3	10'-1"	13'-5"	10-35	3	6-24	1-2
CF-12-UF	12	4	10'-8"	14'-0"	15-60	3-6	6-24	1-2
CF-19-UF	19	5	11'-5"	14'-9"	30-95	6	6-24	1-2
CF-28-UF	28	6	12'-4"	15'-8"	42-140	6-10	6-24	2-3
CF-38-UF	38	7	13'-4"	16'-8"	60-190	6-10	6-24	2-3
CF-50-UF	50	8	14'-0"	17'-4"	75-250	10-15	6-24	2-3
CF-64-UF	64	9	15'-0"	18'-4"	100-320	10-15	6-24	2-3